

HEEPocrates: An Ultra-Low-Power RISC-V Microcontroller for Edge-Computing Healthcare Applications

Embedded Systems Laboratory (ESL), EPFL,
Lausanne, Switzerland

Contacts:	Simone Machetti, Pasquale Davide Schiavone, Thomas Christoph Müller, Alexandre Levisse, Miguel Peón-Quirós and David Atienza
E-mail:	simone.machetti@epfl.ch
Technology:	TSMC 65nm LP MS/RF
Die Size:	2mm x 3mm
Design Tools:	Siemens Questasim, Synopsys Design Compiler, Cadence Innovus

Application Area: Healthcare

Introduction

The field of edge computing in healthcare has seen remarkable growth due to the increasing demand for real-time processing of data in applications. However, challenges persist due to limitations in healthcare devices' performance and power efficiency. To overcome these challenges, heterogeneous architectures that combine host processors with specialized accelerators have emerged, leading to improved performance and power consumption.

In this work, we present HEEPocrates, an ultra-low-power RISC-V microcontroller for edge computing healthcare applications. The chip combines the open-source eXtensible Heterogeneous Energy-Efficient Platform (X-HEEP)^[6] with a coarse-grained reconfigurable array (CGRA)^[3] and in-memory computing (IMC)^[7] accelerators, both of which are efficient in reducing the energy consumption of healthcare applications^[2].

Description

Figure 1 shows the HEEPocrates architecture and how the CGRA^[3] and IMC^[7] accelerators are integrated.

The X-HEEP host platform^[6] is configured with:

- 1) a CV32E20 core^[5], which is optimal for running control tasks and offloading performance-intensive computations to the external accelerators;
- 2) 8 SRAM banks of 32 KiB to accommodate variable lengths of data while power-gating the unused banks;
- 3) a fully connected bus to provide high-bandwidth capabilities to the CGRA^[3];
- 4) all the available peripherals in place to deliver high flexibility;
- 5) a CGRA^[3] and IMC^[7] accelerators connected to the external eXtensible Accelerator InterFace (XAIF).

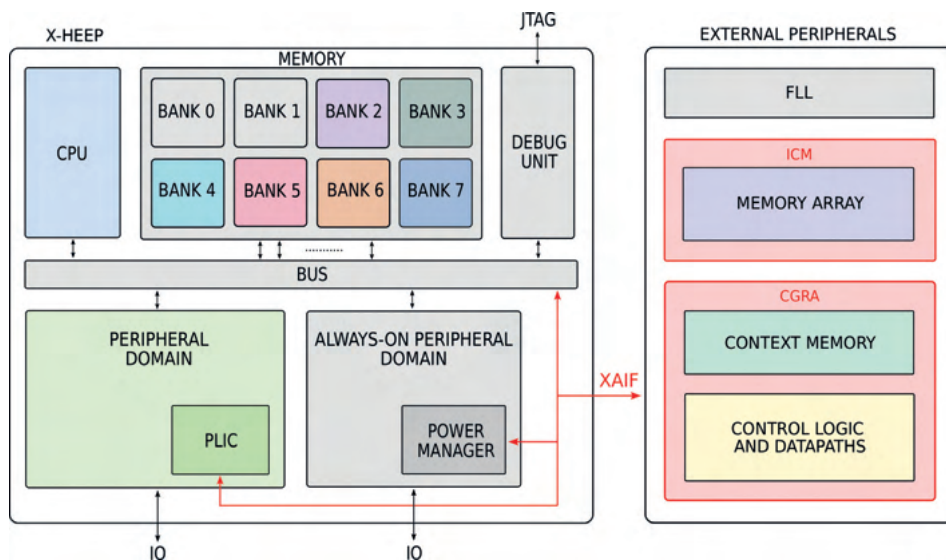

Fig.1: HEEPocrates architecture. Power domains are visually marked using different colors. The components highlighted in grey are always on. The accelerator integration is marked in red.

The design includes 11 power domains, marked with different colors, which can be independently clock-gated or power-gated when unused to reduce power consumption. Memory banks can also be set in retention mode.

Results

Figure 2 shows the HEEPocrates layout, the silicon photo, and the physical realization. The chip has been tested from 0.8 V to 1.2 V, achieving a maximum frequency of 170 MHz and 470 MHz, respectively. The power consumption ranges from 270 μ W in 32 kHz and 0.8 V, to 48 mW at 470 MHz and 1.2 V.

To validate the design, we measured the energy consumption of healthcare applications running on the host CPU of HEEPocrates and on state-of-the-art microcontrollers commonly adopted in this application domain.

The selected microcontrollers cover the spectrum of ultra-low-power edge devices, ranging from top-tier power efficiency, with

Apollo 3 Blue, to top-tier performance, with GAP9. Similarly, the benchmark covers the spectrum of ultra-low-power healthcare applications, ranging from acquisition-dominated, with heartbeat classifier^[1], to processing-dominated, with CNN for seizure detection^[4].

We have measured each application phase at each microcontroller's optimal frequency and voltage configuration. For HEEPocrates, we have run acquisition phases at 1 MHz, 0.8 V to reduce power while offering enough performance to acquire bio-signals in the order of hundreds of Hertz, and processing phases at the maximum speed of 170 MHz, 0.8 V to minimize processing time and race to sleep.

Figure 3 shows the energy alignment of HEEPocrates with the selected microcontrollers for both computationally hungry and acquisition-dominated healthcare applications. This demonstrates the real-world suitability of the chip for this application domain, known for its strict power and performance constraints.

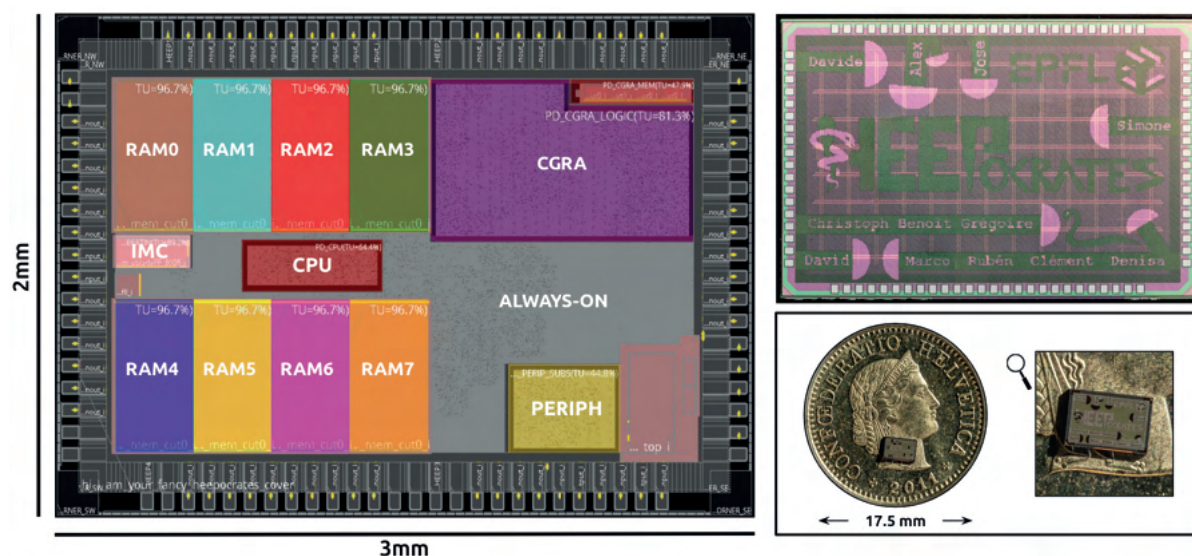

Fig.2: HEEPocrates layout, silicon photo, and physical realization (on a Swiss 5-cent franc coin).

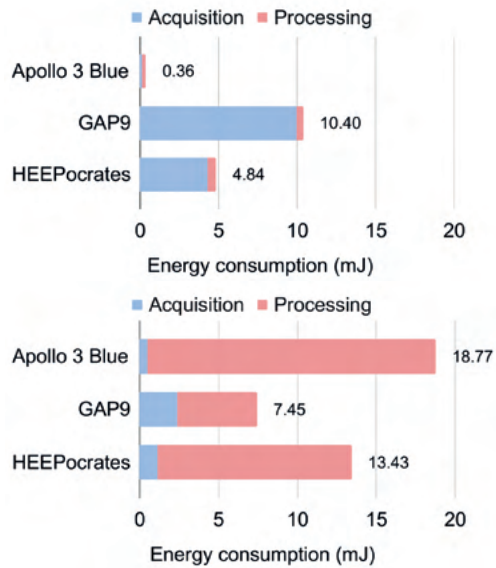

Fig.3: Energy consumption of the benchmark running on relevant healthcare microcontrollers and on HEEPocrates. (a) Heartbeat Classifier. (b) Seizure Detection CNN.

Why EURORACTICE?

EUROPRACTICE support is a key element in the success of this project. Their assistance in acquiring EDA tool licenses, access to technology design kits, participation in their mini@sic MPW program, and the design support from their team, which addresses all sorts of tricky questions, are extremely valuable for universities. Having such a partner is a great asset for EPFL, enabling high-quality research on systems-on-chips (SoC).

References

- [1] Rubén Braojos, Giovanni Ansaloni, and David Atienza. A methodology for embedded classification of heartbeats using random projections. In DATE, pages 899-904. IEEE, May 2013.
- [2] Elisabetta De Giovanni, Fabio Montagna, Benoît W. Denkinger, Simone Machetti, Miguel Peón-Quirós, Simone Benatti, Davide Rossi, Luca Benini, and David Atienza. Modular design and optimization of biomedical applications for ultralow power heterogeneous platforms. IEEE Transactions on Computer-Aided Design of Integrated Circuits and Systems, 39(11):3821-3832, 2020.
- [3] Loris Duch, Soumya Basu, Rubén Braojos, David Atienza, Giovanni Ansaloni, and Laura Pozzi. A multi-core reconfigurable architecture for ultra-low power bio-signal analysis. In IEEE BioCAS, pages 416-419, 2016.
- [4] Catalina Gómez, Pablo Arbeláez, Miguel Navarrete, Catalina Alvarado-Rojas, Michel Le Van Quyen, and Mario Valderrama. Automatic seizure detection based on imaged-eeeg signals through fully convolutional networks. Scientific reports, 10(1):1-13, 2020.
- [5] Pasquale Davide Schiavone, Francesco Conti, Davide Rossi, Michael Gautschi, Antonio Pullini, Eric Flamand, and Luca Benini. Slow and steady wins the race? a comparison of ultra-low-power risc-v cores for internet-of-things applications. In Int. Symp. on Power and Timing Modeling, Optimization and Simulation (PATMOS), pages 1-8. IEEE, 2017.
- [6] Pasquale Davide Schiavone, Simone Machetti, Miguel Peón-Quirós, Jose Miranda, Benoît Denkinger, Thomas Christoph Müller, Ruben Rodríguez, Saverio Nasturzio, and David Atienza Alonso. X-heap: An open-source, configurable and extendible RISC-V microcontroller. In Proc. of Int. Conf. on Computing Frontiers, CF '23, pages 379-380, New York, NY, USA, 2023. ACM.
- [7] William Andrew Simon, Yasir Mahmood Qureshi, Marco Rios, Alexandre Levisse, Marina Zapater, and David Atienza. Blade: An in-cache computing architecture for edge devices. IEEE Transactions on Computers, 69(9):1349-1363, 2020.